

FLYING WITH YOUR POWERCHAIR

March 2024

Flying with your Magic Mobility wheelchair

Mobility aid weight

The weight of the wheelchair varies greatly with the options fitted. Generally, the weight can be between 130 and 220kg.

PLEASE PRINT DOCUMENT AND PROVIDE TO YOUR AIRLINE

IATA Transport Declaration of Conformity

Magic Mobility hereby declares the compliance of its non-spillable, batteries with international transport regulations. These batteries, designed with a gelled electrolyte and an AGM separator, meet the Class 8 UN classification UN2800 and adhere to D.O.T., IMO/IMDG, and ICAO/IATA standards.

Conformities

- **Air Transport Compliance:** Meets IATA/ICAO Special Provision A67, passing all required vibration and pressure differential tests, and is thereby not restricted for air transport.
- **Maritime Transport Compliance:** Aligns with IMO/IMDG Special Provision 238, passing all required vibration and pressure differential tests unrestricted sea vessel transport.
- **US Regulation Adherence:** Complies with 49 CFR 173. 159.

Models

- MM-06285/6-EVF-100
- MM-06654/6-EVF-80
- MM-BATT73MK

Safety and handling instructions

- Protection against short circuits is mandatory.
- Batteries must be labeled as "Non-Spillable" or "Non-Spillable Battery".
- A visual inspection should confirm no evident defects or damage.

Wheelchair battery installation

1. When installed in a wheelchair, batteries must be disconnected from the power module with the leads covered to prevent short circuits.
2. Batteries that are removed should either be securely attached to the wheelchair aid or placed in strong, rigid packaging, labelled "Non-Spillable" or "Non-Spillable Battery".
3. Additional Note: Airline policies may vary; travellers are advised to consult the airline's website for specific battery transport requirements.

To prepare your Magic 360 for flying:

Step 1: Disconnect the batteries from the power module.

To isolate the batteries and put the wheelchair in safe mode for flying, remove the lead from the power module.

<ul style="list-style-type: none"> ● Power Module (PM) is normally located on base at rear of chair. ● Undo two thumb screws. 	<ul style="list-style-type: none"> ● Remove plastic cover. ● Battery connector indicated with sticker. 	<ul style="list-style-type: none"> ● Disconnect and cover with tape. ● Cover can be reattached for transport.

Step 2: Put the motors in freewheel mode.

Once the power module has been isolated from the batteries, the wheelchair is hard to push manually. The motor brakes need to be disengaged. The motor brakes must be re-engaged to allow the user to operate the wheelchair.



There's no braking on your powerchair when it's in freewheel mode. Be sure to turn the power off before disengaging the motor brakes.

Two motor release levers are located on the rear. To disengage the built-in or "running" brakes simply pull the levers towards you.

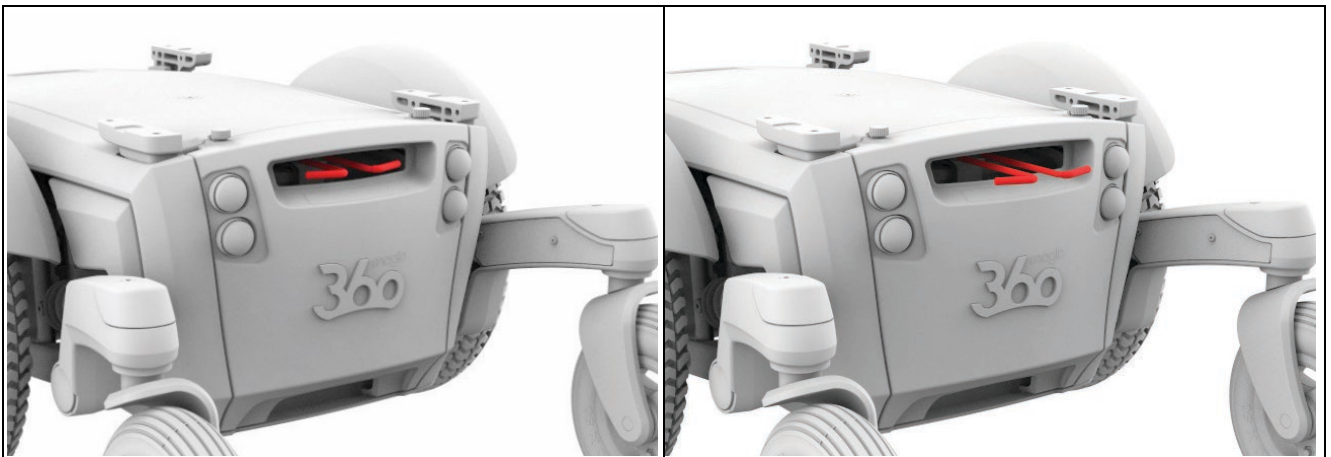

Magic 360 brake levers engaged

Magic 360 brake levers released

To prepare your Extreme X8 for flying:

Step 1: Disconnect the batteries from the power module.

To isolate the batteries and put the wheelchair in safe mode for flying, remove the lead from the power module.

<ul style="list-style-type: none"> ● Power Module (PM) is normally located on base at rear of chair. ● Undo two thumb screws. 	<ul style="list-style-type: none"> ● Pull PM clear of rear mounts. ● Battery connector indicated with sticker. 	<ul style="list-style-type: none"> ● Disconnect and cover with tape. ● PM can be reattached for transport.

Step 2: Put the motors in freewheel mode.

Once the power module has been isolated from the batteries, the wheelchair is hard to push manually. The motor brakes need to be disengaged. The motor brakes must be re-engaged to allow the user to operate the wheelchair.



There's no braking on your powerchair when it's in freewheel mode. Be sure to turn the power off before disengaging the motor brakes.

Motor release levers are located at the rear. The two levers must be clicked down to release the motors.

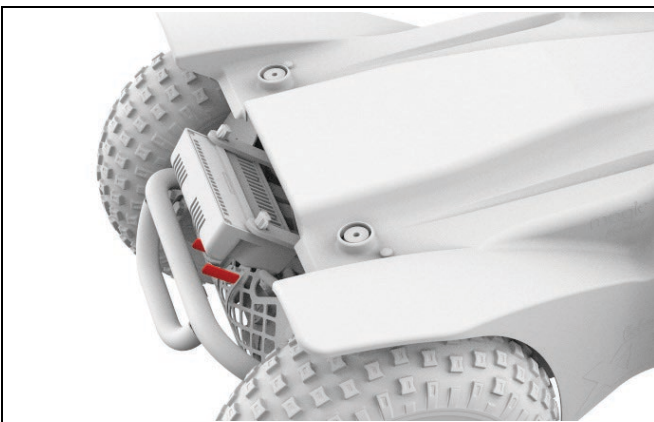

Extreme X8 brake levers engaged

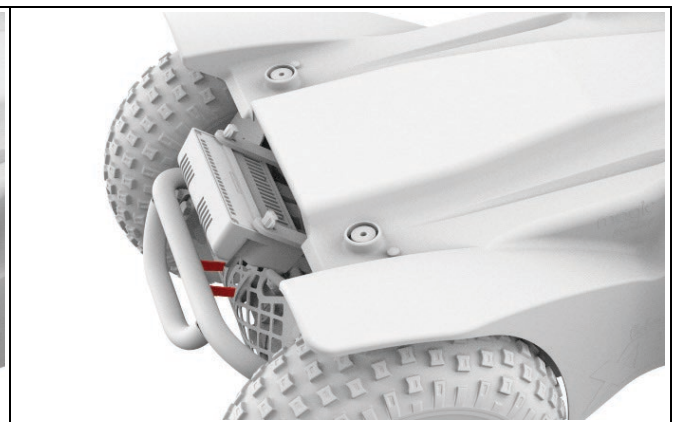

Extreme X8 brake levers released

To prepare your Frontier for flying:

Step 1: Disconnect the batteries from the power module.

To isolate the batteries and put the wheelchair in safe mode for flying, remove the lead from the power module.

<ul style="list-style-type: none"> ● Power Module (PM) is normally located on base at rear of chair. (RWD is at front.) ● Undo thumb screw. 	<ul style="list-style-type: none"> ● Allow cover to drop to reveal PM connections. ● Battery connector indicated with sticker.
<ul style="list-style-type: none"> ● Disconnect battery lead. 	<ul style="list-style-type: none"> ● Cover with tape. ● Cover can be reattached for transport.

Step 2: Put the motors in freewheel mode.

Once the power module has been isolated from the batteries, the wheelchair is hard to push manually. The motor brakes need to be disengaged. The motor brakes must be re-engaged to allow the user to operate the wheelchair.



There's no braking on your powerchair when it's in freewheel mode. Be sure to turn the power off before disengaging the motor brakes.

FRONTIER V6 and V4

Motor release levers are located at the front of each drive wheel. To disengage the built-in or “running” brakes simply push the down levers on each side.

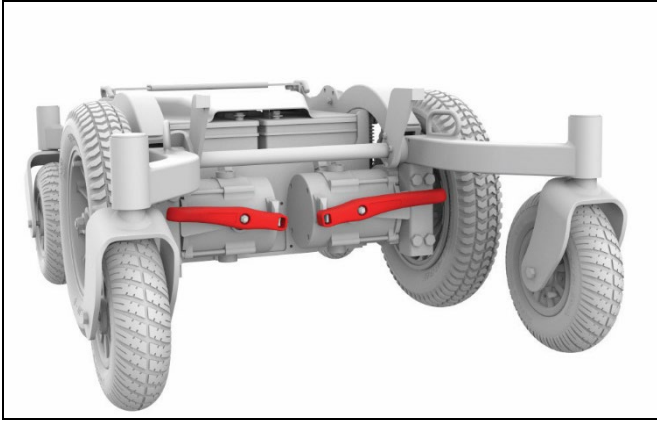

Frontier V6 brake levers engaged

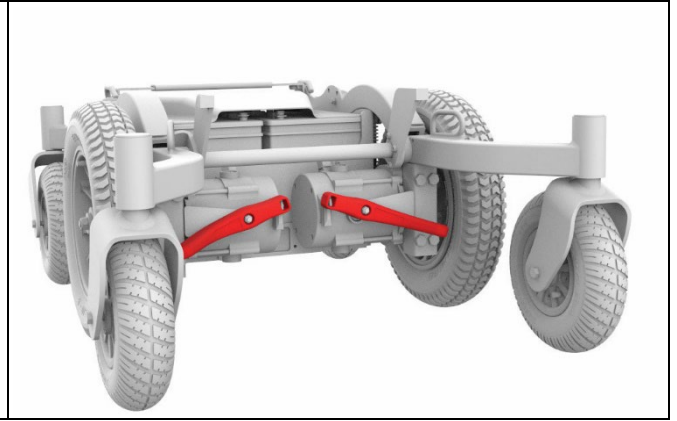

Frontier V6 brake levers released

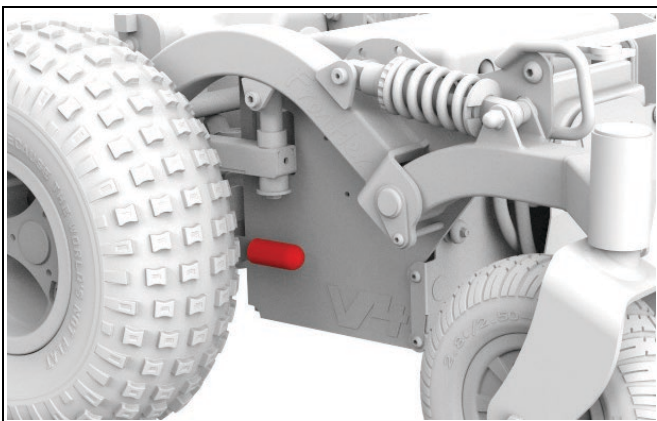

Frontier V4 brake levers engaged

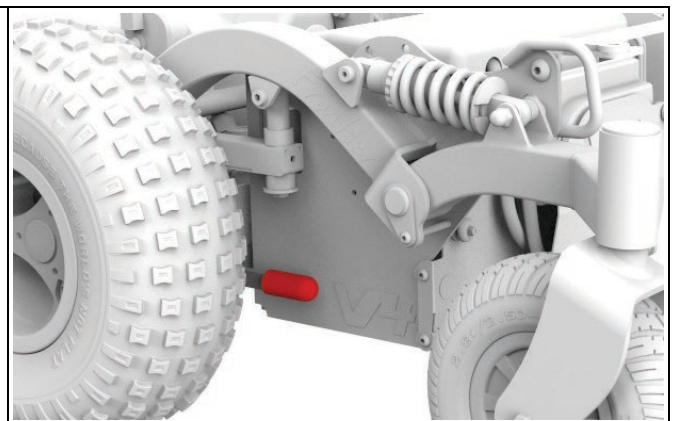

Frontier V4 brake levers released

To prepare your XT for flying:

Step 1: Disconnect the batteries from the power module.

To isolate the batteries and put the wheelchair in safe mode for flying, remove the lead from the power module.



- Batteries can be disconnected via the lever.
- Lever centralises.
 - Move left (red) to disconnect batteries.
 - Move right (green) to connect batteries.

Step 2: Put the motors in freewheel mode.

Once the power module has been isolated from the batteries, the wheelchair is hard to push manually. The motor brakes need to be disengaged. The motor brakes must be re-engaged to allow the user to operate the wheelchair.



There's no braking on your powerchair when it's in freewheel mode. Be sure to turn the power off before disengaging the motor brakes.

Motor release levers are located at the rear. The two levers must be clicked down to release the motors.

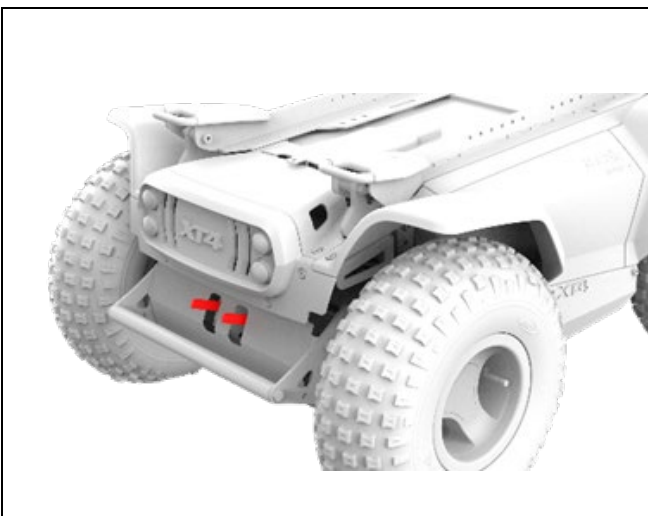

XT2 and XT4 brake levers engaged

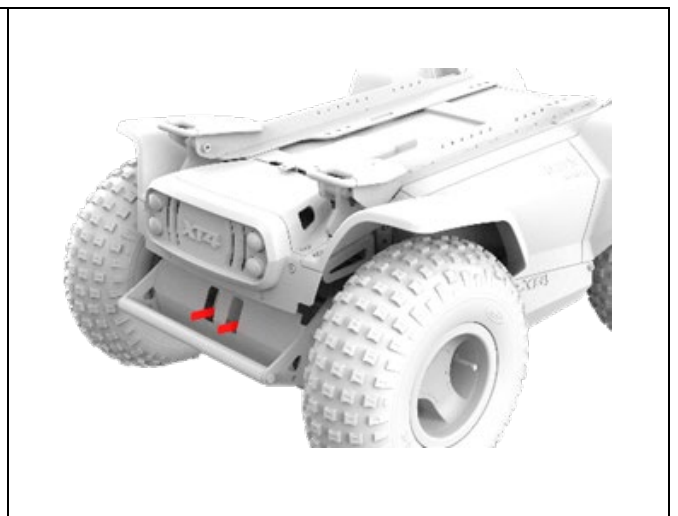

XT2 and XT4 brake levers released

Contact Magic Mobility if you require further information:

3 International Court, Scoresby Vic 3179
Tel +61 3 8791 5600

Email enquiries@magicmobility.com.au
Web <http://www.magicmobility.com.au>